

table of content

general installation manual

1.	regulations/guidelines	01
2.	technical documentation	01
3.	unloading	01
3.1	inspection of the goods	01
3.2	unloading process	01
4.	storage	03
5.	qualification requirements for installation companies	03
6.	general rules and notes	03
6.1	inspection of the support construction/preceding craft	03
6.2	inspection of the sandwich panels	03
6.3	sealing	03
6.4	protective foil	03
6.5	protection of the coating	03
6.6	repair of minor damages	04
6.7	cutting	04
6.8	drilling	04
6.9	applicable tools	04
6.10	professional damage repair	04
6.11	final inspection	04
7.	general installation rules	05
7.1	start of installation	05
7.2	alignment of the panels	05
7.3	fixation of the panels	05
8.	additional notes	06
8.1	possible panel combinations	06
8.2	connections	06
8.3	certificate of conformity	06



1. Regulations/guidelines

When installing Metecno-sandwich panels the following rules and guidelines must be followed:

- general building permits/ general building-type permits for Metecno-sandwich panels
- Metecno installation manuals and guidelines
- accident prevention regulations
- IFBS-rules for metal construction



2. Technical documentation

The following documents are required for proper building and installation works:

- CE-or Ü-mark: these labelling documents, which prove the conformity with national and international regulations, must be retained and kept ready for possible inspection at the construction side
- layout-and working drawings/cutting lists: these documents must be kept available at the construction site at all time for prove of stability, fitness of purpose and constructive specification
- statical calculations and load-bearing tables (if necessary, with release note by statical engineer)
- official general building permits for sandwich-panels and fixing-material
- installation manuals

3. Unloading

3.1 Inspection of the goods

Check, if the delivered sandwich panels are undamaged and complete. Any claims are to be marked immediately on the CMR in the presence of the truck driver. This is also applicable for accessories. Non-recognizable damages are to be claimed within 6 days in written form. Any labels and copies of transport documents are to be kept available with the remaining building documents on site.

3.2 Unloading process

Packages with lengths up to 6,00 m

Such packages may be unloaded with forklifts with adjustable fork-distance. The minimum fork-width must be 150mm. To protect the edges and bottom side of the packages, corner protections are to be used.

(see page 02)



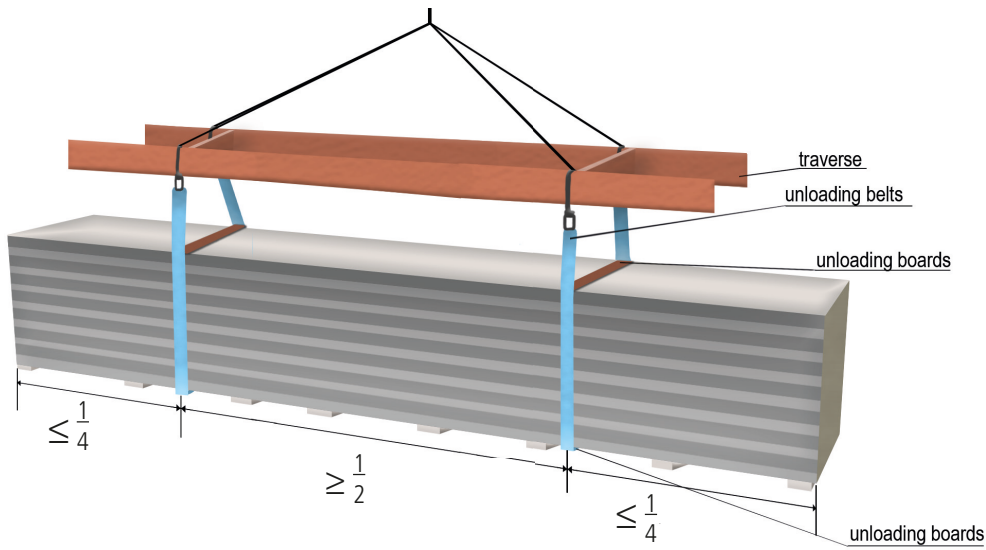

Packages with lengths from 6,00 to 12,00 m

Unloading with traverse with 2 attachment points

Maximum overlap: $\frac{1}{4}$ of total package length

Minimum distance between attachment points: $\frac{1}{2}$ of total package length

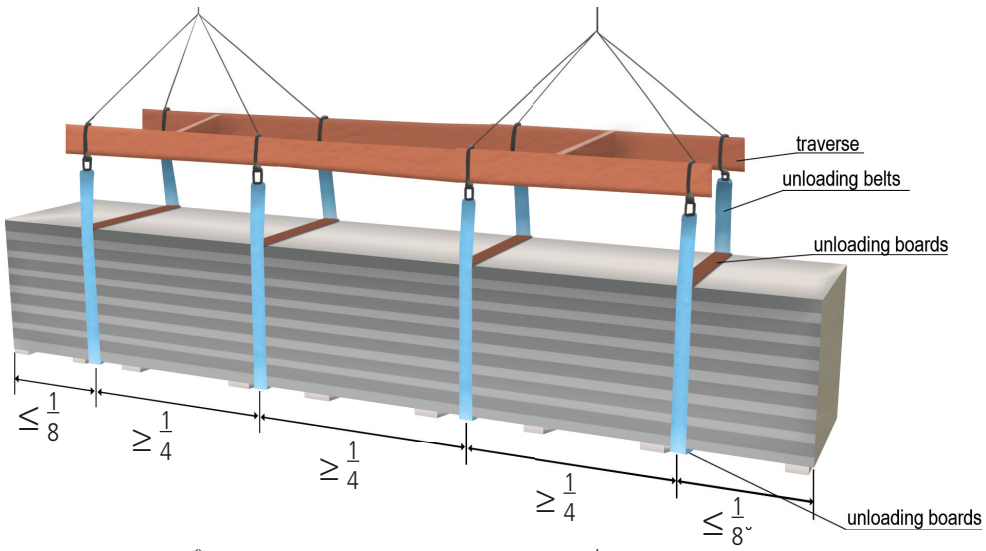

Packages with lengths greater than 12,00 m

Unloading with traverse with 4 attachment points (alternatively with 2 traverses with 2 attachment points)

Maximum overlap: $\frac{1}{8}$ of total package length

Minimum distance between attachment points: $\frac{1}{4}$ of total package length

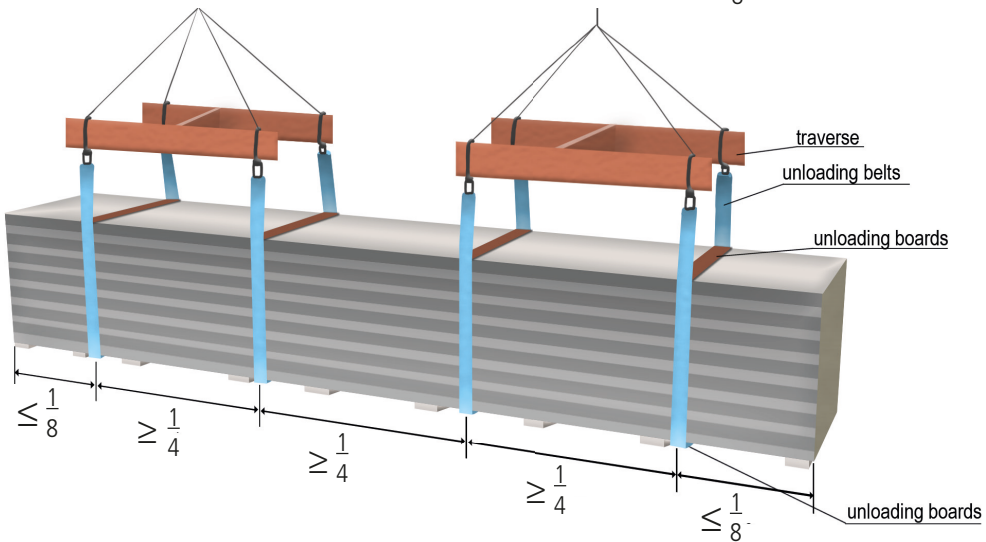

length of package	length of overlap	distance between attachment points
12,00 to 16,00 m	1,50 m to 2,00 m	3,00 m to 4,00 m
16,00 to 20,00 m	2,00 m to 2,50 m	4,00 m to 5,00 m
20,00 to 25,00 m	2,50 m to 3,00 m	5,00 m to 6,50 m

The load-bearing capacity of each unloading-variant needs to be checked according the individual package weight.



4. Storage

Packages are to be stored on plane and firm ground so they are protected from soiling, humidity and damages. Furthermore, packages must be stored with a longitudinal slope of min. 5% avoiding stagnant water, which may cause permanent damages such as spots, corrosion or white rust. Cutting the packaging material on the front ends of the packages avoids condensation.

The sandwich-panels are to be protected from the influence of weather, especially from rain and UV-exposure. To avoid permanent deformation or dents max.2 packages must be stored over each other. Additional storage supports may be necessary.

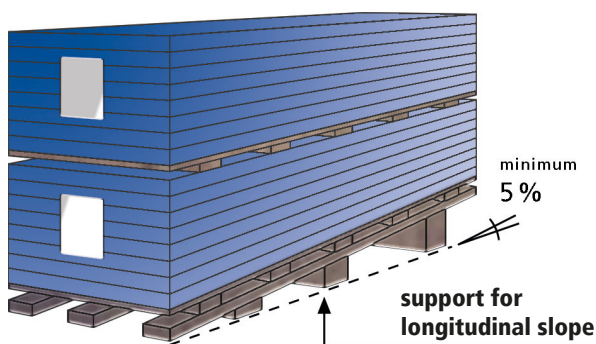

In case of storage of the packages directly on the roof, permission of the local site supervisor must be granted. Packages must be stored only on load-distributing support. Total load must not exceed the maximum load bearable by the support construction. Packages/panels are to be secured against gliding off. In case of interruption of installation work, open packages must be secured against wind exposure.

5. Qualification requirements for installation companies

Proof for qualification of installation works:

- Membership at a chamber of handicrafts for this specific sector/operation
- Proof of legal liability insurance of the executing company
- Proof of liability, health & social insurance for employees of executing company
- Proof of experience/good practice with the installation of sandwich panels (e.g. quality mark of IFBS, etc...)

6. General rules and notes

6.1 Inspection of the support construction/preceding craft

To approve levelness of wall and roof-surfaces made of sandwich panels, the support construction must be thoroughly checked for rectangularity, flatness, alignment, necessary support width, etc... respecting the tolerances of the preceding craft and IFBS-rules for metal construction. All support-surfaces must be continuously plane.

The slope of roof-beams must correspond with the slope of the roof. In case of deviation, adjustment action (e.g. shimming) is to be taken to ensure levelness of the support construction. If not done so, sandwich panels may show deformations compromising their load bearing capabilities as well as their usability in respect of visual appearance.

Constructive minimum support width is 40mm at end bearings and 60mm at intermediary bearings. Higher support widths may be necessary due to static requirements.

Installation of sandwich panels can be done on:

- wooden support construction
- steel support construction
- firmly seated HTU-rails into concrete or ferroconcrete

6.2 Inspection of the sandwich panels

Before installation all sandwich panels must be checked for correct proportions such as length, width and geometry.

6.3 Sealing

Prior to installation all necessary sealing tapes are to be applied according to drawings/installation manual. To avoid thermal loss and condensation, all connections must be executed airtight. Cavities must be insulated with foam or mineral wool.

6.4 Protective foil

Our sandwich panels come with protective foil which needs to be removed during installation as it is designed for short dwell time only. Since adhesion to the panels surface constantly increases, panels and foil must be protected from direct sun exposure. Temperatures lower than 10°C may impede the removal of the protective foil. Panel surfaces and flashings need to be thoroughly cleaned of drilling-and cutting-chips during and after installation to avoid rust bloom and damages on the surface. For minor damages of the coated surface (e.g. scratches) touch-up-paint is to be used for repair.

6.5 Protection of the coating

The coated surface of sandwich panels and flashings must be thoroughly cleaned of drilling/cutting chips after installation to avoid rust bloom and damages on the surface.



6.6 Repair of minor damages

In case of minor damages (e.g. scratches) during unloading or handling, touch-up-paint (which comes with the panels) is to be used for repair. Due to different methods between industrial coil coating and manual coating, color differences cannot be avoided in most cases.



For more extensive recoating a professional company should be commissioned. At best, such a company should be able to perform a color assimilation.

6.7 Cutting

Cutting of sandwich panels can be performed with a jigsaw or circular handsaw. Saw blades should have fine toothwork and should produce a cold cut. For flashings tin nibblers and metal shears are the tools of choice.

Since fast-rotating saws or power-cutters burn the corrosion protection of the organic coating and zinc-layer, the use of such tools is strictly forbidden in order to avoid additional treatment of the cutting edges.

Cutting edges of surface-improved steel sheets must always be ventilated sufficiently so cathodic protection is not impaired. Due to DIN 55634 additional protection for cutting edges is not necessary for steel thicknesses up to 1,5mm.

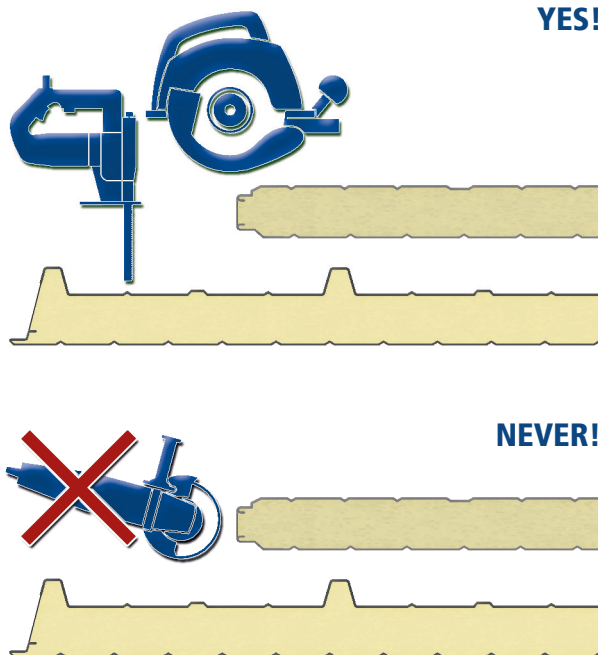

6.8 Drilling

Drilling chips on visible and exposed surfaces are to be removed immediately since they lead to discoloration and damages of the coated surface.

6.9 Tools

For proper installation of Metecno- sandwich panels the use of the following tools is recommended:

- Lifting tools for safe transporting and positioning of the sandwich panels. Since special lifting tools with vacuum cups produce local peak loads during transport and handling, the use of such tools must be coordinated with the supplier of such tools, especially when installing sandwich panels with mineral wool core.
- Lifting clamps (e.g. Condor Grip lifting clamp of Carl Stahl Hebeteknik GmbH) or Vacuum lifting traverses (e.g. VIAVAC vacuum lifting bv) for installation of roof panels
- Sling gear for lifting wall panels for horizontal and vertical installation
- Pressing tools for the installation of wall panels to assure an airtight closure of the joint

Manual for download



SCAN ME

- slow-moving circular handsaws and jigsaws for cutting
- standard power drillers with sharp drills
- drillers especially developed for such type of construction. These drillers have a depth stop and ensure an adequate and professional tightening of the screws
- tin nibblers and metal shears for cutting of sheets with a cold cut
- riveting machines for connecting steel sheets (e.g. flashings)

6.10 Professional damage repair

- untight screw/dry borehole: remove screw and replace it with new screw with diameter next in size
- inclined screw: remove screw, fill borehole with sealing for sandwich panels and close hole with repair screw. New fixing must be performed with a distance of at least 20mm to original/repaired fixing point
- scratches: use touch-up-paint, provide primer-coating if necessary; take possible color deviations into account
- soiled surfaces: clean surface with cloth, soft brush and water
- ragged cutting edges after cut with saw: mechanical burring of cutting edges, then treatment of the edges with primer and touch-up-paint

6.11 Final inspection

After completion of sandwich-panel installation works an immediate final inspection for transfer of perils is recommended. An intermediate inspection is clearly recommended in case parts of the building/construction are used by a different company.

7. General installation rules

7.1 Start of installation

Installation of the panels must be performed according layout-drawing specifically designed for the particular building project. The panels must be installed perpendicular and properly aligned while sticking to installation tolerances according DIN 18202 and IFBS-general rules. Prior to installation of the panels all internal flashings and cover profiles incl. sealing tapes must be installed. Sealing tapes must be pressed-in and aligned thoroughly to avoid thermal bridges and condensation.

Cavities must be filled with sealing tapes, PUR-foam or mineral wool to procure desired leak/air-tightness of the building. To ensure sufficient pressing of the sealing tapes (and therefore the sufficient tightness of the joints) the use of pressing tools is recommended (see Metecno pressing-tool in section 6.9.). In order to avoid deformation, deflection and punctual loads, panels must be transported upright using appropriate working gloves.

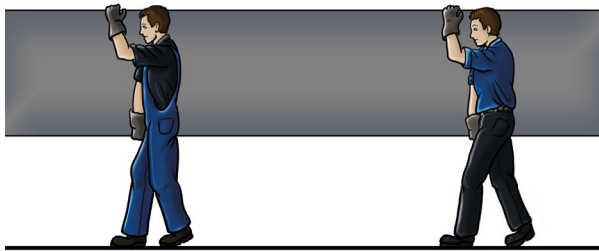

All connections must be executed wind-and rainproof

7.2 Alignment of the panels

The first panel must be aligned perfectly and must be checked for levelness and perpendicularity. These values (as well as the stated panel width) must be double-checked after installation of a few succeeding panels.

7.3 Fixation of the panels

For the fixing of sandwich panels only screws according general building permit Z-14.4-407 or European-technical approval (ETA) must be used. Stainless steel screws must have a minimum diameter of 5,5mm, the washers must have a minimum diameter of 16mm. To reduce the possibility of bulges and for better load-distribution, washers with bigger diameter may be used. For hidden fixing the size of the washers is limited. By using screws with supportive thread, the bulging of the steel sheets can be reduced. When installing roof panels, additional saddle caps may be used.

The number of screws is depending on the statical requirements, though not less than 2 screws per support-line must be used. For best fixing results the screw must be inserted up to the point when the sealing of the screw-head starts deforming slightly. All screws must be applied rectangular to the roof or wall panels to assure the washers are fully facing the surface of the panel. The minimum thread reach for wooden support-construction is 50mm, though different thread reaches may be stated in the relevant building permits/ETAs. Intruding or penetrating screws may be visible and must be covered properly on the internal sides of buildings with room heights below 2,50m to avoid risk of injury.

Hidden fixing is possible for:

- wall panels (PUR) Superwall ML and H-Wall 8P according to Z-10.49-516 and Z-10.4-583
- wall panels (mineral wool) Superwall HF according Z-10.49-517
- wall panels (glass wool) Metfiber Eco Wall HF according Z-10.49-613



8. Additional notes

8.1 Possible panel combinations

Metecno-sandwich panels are combinable as follows:

Roof panels:

G4 roof panels (PUR) can be combined with Hipertec Roof panels (mineral wool). However, manual adjustment of the internal joint is necessary.

At the transition from Hipertec Roof to G4 the joint must be press-insulated. At the transition from G4 to Hipertec Roof the tongue must be cut-off locally

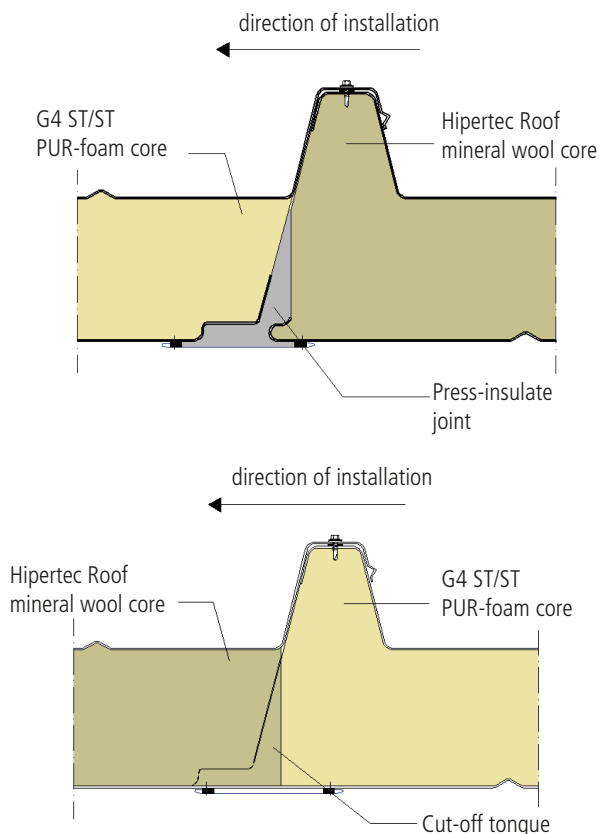

8.3 Certificate of conformity

The installing company needs to confirm the professional execution of all installation work (according to general building permit or other local regulations) in accordance with the issued building permission (regulations, workmanship and handling procedures, statical calculations) and needs to hand this certificate over to the principal after completion of installation work.

Wall panels – visible fixing

Wall panels (PUR) Thermowall Kombi are combinable with wall panels (mineral wool) Hipertec Wall and wall panel (glass wool) Metfiber Eco Wall. These panels have an identical joint construction and no additional steps must be taken when combining them.

Wall panels – hidden fixing

Wall panels (PUR) Superwall ML are combinable with wall panels (mineral wool) Superwall HF and wall panel (glass wool) Metfiber Eco Wall HF. These panels have an identical joint construction and no additional steps must be taken when combining them.

8.2 Connections

All connections for roof-and wall sandwich panels must be done according to Metecno detail drawings and IFBS-rules.

